

WebControl™

Programmable Logic Controller

User Guide

Version:	3.2.15
Hardware Version:	2.2.2
Firmware Version:	3.2.15
Date last modified:	10/10/2012

Table of Contents

1	Introduction	1
1.1	Scope.....	1
1.2	Table of Definitions	1
2	WebControl™ I/O.....	2
2.1	Power Supply Inputs.....	2
2.2	TTL Output Port.....	2
2.3	AUX Input Port.....	3
2.4	1-Wire Sensor Input.....	3
2.5	Humidity Sensor Input	3
3	WebControl™ PLC Web GUI Configuration	5
3.1	Network Settings.....	5
3.2	Access Settings	6
3.3	I/O Setup.....	6
3.4	X10 RF Control	8
3.5	Output Control	9
3.6	Email Notification Setup.....	10
3.7	General Setup.....	12
3.8	Reset Setup	13
4	AUX System Inputs.....	14
4.1	Digital Inputs	14
4.2	Analog Inputs.....	15
4.3	DS1822/DS18B20 1 Wire Temperature Sensors	15
4.4	Honeywell 4000 Series Relative Humidity Sensor.....	16
4.5	Timers.....	16
4.6	Direct Query System Inputs and Outputs	17
5	Real Time Clock.....	18
5.1	Network Requirements to Use the NTP.....	18
5.2	Realtime Clock Use DS2417	18
6	WebControl™ PLC Programming	19
6.1	The Basics of PLC Programming	19
6.2	WebControl™ PLC Instructions	20
6.3	WebControl™ PLC I/O Identifiers	23
6.4	WebControl PLC Examples	24
6.4.1	Example 1 Set Output based on condition	25
6.4.2	Example 2: Flash TTL output	25

6.4.3	Example 3: Push Button Input Control Output.....	26
6.4.4	Example 4: Send EMAIL	26
6.4.5	Example 5, Parallel I/O.....	27
6.4.6	Example 6, Sequential I/O.....	28
6.4.7	Example 7, Traffic Lights	29
6.4.8	Example 8, Time based Control	31
6.4.9	Example 9, Battery Charger	33
6.4.10	Example 10, RFID reader and browser Control	34
6.4.11	Example 11, Your Examples	35
7	WebControl™ PLC FAQ	36
7.1	Login and Configuration.....	36
7.2	Temperature Sensor Support	36
7.3	Turn on/off TTL output from another programming language.....	37
7.4	External Analog Chip DS2450	38
7.5	Power Supply Requirement	38

Table of Figures

Figure 1.0 WebControl™ PCB inputs and outputs diagram	2
Figure 2.0 WebControl™ sensor connection	3
Figure 3.0 WebControl™ PLC system status.....	5
Figure 4.0 WebControl™ PLC Network configurable	6
Figure 5.0 I/O setup	7
Figure 6.0 WebControl™ X10RF Control.....	8
Figure 6.0 WebControl™ Output Control	9
Figure 7.0 WebControl™ email setup	10
Figure 8.0 Network defaults	12
Figure 9.0 WebControl™ J12 Input pins	14
Figure 10.0 WebControl™ Temperature sensor assignments	15
Figure 11.0 DS2417 layout	18

1 Introduction

This document provides an overview of the technical aspects of using WebControl™ PLC. It describes the inputs and outputs offered by the PLC version of the WebControl™ hardware and firmware. The WebControl PLC Programming Guide is found in chapter 6 of this document. Function, usage and syntax as well as many examples are provided there to help you get started. WebControl™ PLC is different from the earlier WebControl™ BRE. The PLC version of firmware provides greater flexibility in I/O control; but in return, expects user to learn programming concepts and write an assembly like PLC program. A PLC program has the ability to read write and compare values of the available inputs, outputs, variables and timers. With a PLC program loaded and running, WebControl™ PLC can operate on its own, without a network connection. The PLC programming module and programming guide are provided for a learn-on-your own experience. Assistance in writing or debugging PLC code is not provided as part of the regular technical support for WebControl™ PLC configuration.

1.1 Scope

The scope of this document is to be a guide for configuring and using the features provided by WebControl™. The reader is expected to be technically competent in all the technical areas within this document, and is strongly advised to use this document alongside the other reference material listed in the reference section.

1.2 Table of Definitions

The following table is a list of definitions used though out the document.

Definition	Description
HTTP	Hypertext transfer protocol
DNS	Domain name server
SMTP	Simple mail transport protocol
SNTP	Simple network time protocol
1-wire	Special bidirectional serial data bus from Maxim
RH	Relative humidity
NetBios	Human readable name used as an alternative to an IP address for accessing the server on a network. E.g. http://WebControl™
IP	Internet protocol
DHCP	Dynamic host configuration protocol
ROM	Read only memory
PLC	Programmable Logic Controller

2 WebControl™ I/O

The current hardware version of WebControl™ is equipped with a number of inputs and outputs; these are shown in below in figure 1.0.

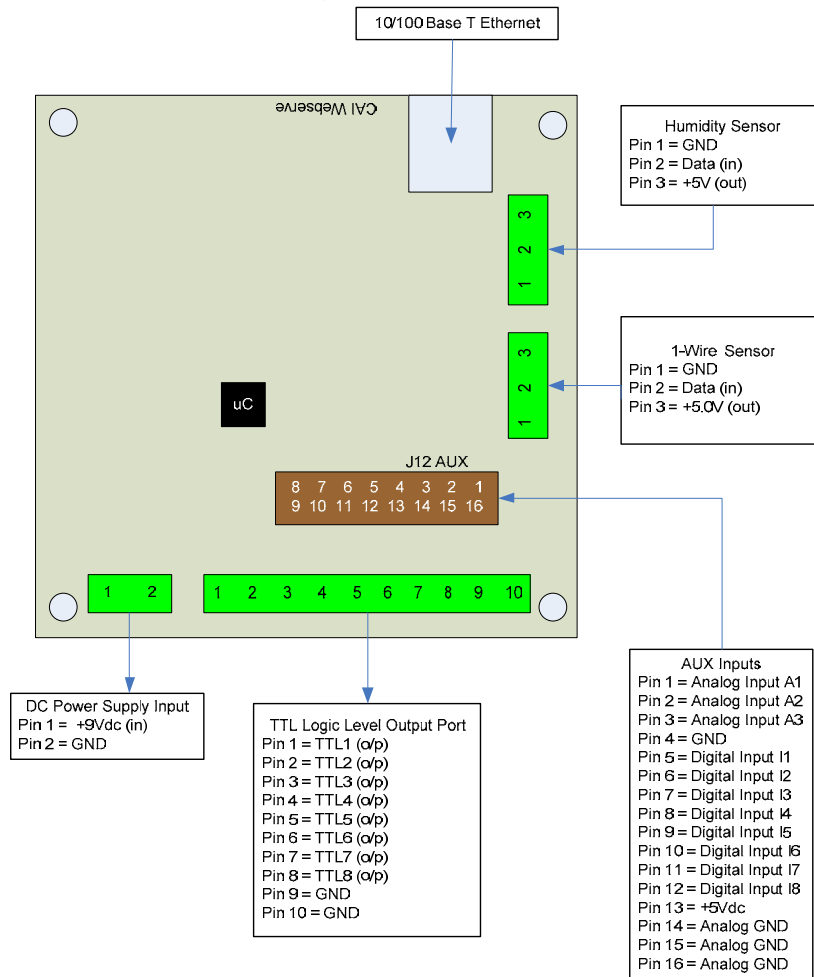

Figure 1.0 WebControl™ PCB inputs and outputs diagram

2.1 Power Supply Inputs

The DC power supply input is the electrical supply to the board. The recommended input voltage is 9V DC. Any voltage greater than 12V applied to this input may require adding heatsink to regulator, otherwise it may overheat.

2.2 TTL Output Port

The TTL logic level output port has 8 TTL outputs that can each be set or cleared using web GUI command codes, or by setting up a PLC using the available inputs, variables, and timers, so that the particular output is set when a particular condition is met. The maximum current that can be sourced or sunk by one of these outputs at a time is 20mA or 100mA for the whole board. TTL 0 level defined as 0-2V, and TTL 1 level is define 3-5V with TTL 0 almost 0V and TTL 1 almost 5V depending on the

load. TTL output current is capable to drive standard solid state relay, but will not be able to drive those coil based relays. Be aware of the current requirements of the circuits/loads attached to these outputs. Damage will occur to the board if too much current is allowed.

2.3 AUX Input Port

The AUX input connector offers digital and analog inputs that can be monitored or programmed to set a single TTL output or several TTL outputs. Three analog inputs are available, each have an input range of 0 to 10Vdc. Eight digital inputs are available and use TTL input levels (0 and 5Vdc). The AUX Input Port pin out diagram (labeled as J12AUX in Figure 1) shows the layout of this port in more detail. The matching connector for this port is TYCO ELECTRONICS - **1658622-3** .

2.4 1-Wire Sensor Input

The 1-wire sensor port allows up to eight Maxim DS1822/DS18B20/DS18S20 1-wire temperature sensors to be connected. It also allows one Maxim DS2417 real time clock, and one DS2450 4 channel A/D converter. The temperature and analog input can be displayed via the HTTP browser and can be used as inputs to the PLC engine to control the TTL output port. Since hardware revision 2.2.2 uses 5V to power 1-wire bus, there is no need for any external power to the sensors. Please note if more than one DS2450 is attached to 1-wire bus, only the first one will be used by the firmware. If more than 10 1-wire devices attached to the bus, only the first 10 will be used.

2.5 Humidity Sensor Input

The current WebControl™ hardware has been designed to use the Honeywell 4000 series relative humidity sensor devices. Using any other humidity sensor without careful consideration may result in malfunction of this feature. The RH sensor can be used to display relative humidity via HTTP or be used to control the TTL outputs as an input in the PLC engine.

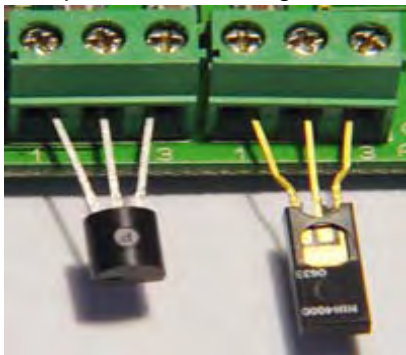

Figure 2.0 WebControl™ sensor connections

Please make sure the temp sensor and humidity sensor connected similar to this picture. Reverse the polarity may cause damage to the board.

3 WebControl™ PLC Web GUI Configuration

To access WebControl™ PLC, connect WebControl™ to the local network and power supply. The default IP address will be 192.168.1.15. Be aware that once you enable DHCP in your WebControl network settings page, you will need to check your DHCP server log for which IP address DHCP assigned to the board. You need to know and understand the network you attaching this hardware to in order to know where to look for DHCP server logs. For home networks, DHCP serving is commonly enabled at the router. Each WebControl™ PLC board has a unique MAC address. Look in the DHCP log to find the matching MAC address, then you can find the IP address DHCP assigned to the hardware. From a computer connected to the same network, start a web browser, and point to that IP address: for example: <http://www.xx.yy.zz> when the web page loads, you will be prompt for login. The default user ID and password is: “**admin/password**”, all in lower case. You will see this page once logged in:

CAI WebControl PLC

Version: v03.02.14 IpAddress: 192.168.1.15 Name: WEBCONTROL 09/06/2012 11:57:22

System Status

Outputs								
	1	2	3	4	5	6	7	8
TTL Output Bits	0	0	0	0	0	0	0	0
32 Bit Signed Vars	0	0	0	0	0	0	0	0

Inputs								
	1	2	3	4	5	6	7	8
TTL Input Bits	0	0	0	0	0	0	0	0
Temperature Sensors	28.7 C	29.5 C	29.5 C	83.6 F	85.1 F	85.1 F	unbound	unbound
Temperature Sensor Status	ok	ok	ok	ok	ok	ok	unbound	unbound
Analog Inputs	0	0	0	0	0	768	768	512
Humidity Sensor	40 %							
Counter	0							
Frequency	0							

Copyright © 2008-2012 CAI Networks, Inc.

Figure 3.0 WebControl™ PLC system status

3.1 Network Settings

These are the basic settings that need to be configured in order for WebControl™ to work successfully on a network. It may be necessary to connect the board directly to a PC and access it using its default IP address before connecting directly to a live

network in order to configure it correctly. Figure 2.0 shows the connection settings WebControl™ has.

CAI WebControl PLC

Version: v03.00.06 IpAddress: 192.168.12.15 Name: WEBCONTROL 06/29/2010 14:41:30

Network Setup

MAC Address: 00:22:12:A2:00:00

System Status

Output Control

I/O Setup

Email Setup

Temperature Sensor Setup

PLC Program

General Setup

Network Setup

Help

Network Configuration	
NetBIOS Name	webControl
Static IP Address	192.168.12.15
Subnet Mask	255.255.255.0
Gateway	192.168.12.251
Primary DNS Server	208.201.224.11
Secondary DNS Server	208.201.224.33
Username	admin
Password	password
DHCP Enabled	<input type="checkbox"/>
Web Login Enabled	<input checked="" type="checkbox"/>
HTTP Port	80

Access Limit	
IP Address 1	192.168.12.108
IP Address 2	1.2.3.4
IP Address 3	2.3.4.5
IP Address 4	3.4.5.6
IP Address 5	4.5.6.7
IP Address 6	5.6.7.8
IP Address 7	6.7.8.9
IP Address 8	7.8.9.0

Send

Copyright © 2010 CAI Networks, Inc.

Figure 4.0 WebControl™ PLC Network configurable

3.2 Access Settings

For security purpose, you can decide your own user name and password. For being used over Internet, you may also set the access list, so that only host in the list can access the WebControl board over the network. Please note that if any entry is 0.0.0.0, all IP addresses can access it.

3.3 I/O Setup

WebControl™ PLC allows users to directly from browser control each output, or through the PLC logic to control the TTL output. For flexibility, user can decide if the

TTL input or out to be inverted between logic 0 and logic 1. To use PLC logic, first user must check the “Global PLC enable” to start the PLC engine. Then for each TTL output, user can decide if the PLC control will be applicable.

CAI WebControl PLC

Version: v03.02.14 IPAddress: 192.168.1.15 Name: WFBCONTROL 09/06/2012 12:07:23

I/O Setup

Global PLC Enable
 X10 Enable
 Counter Enable on TTL Input 1
 Frequency Measurement Enable On on TTL Input 1
 TTL Input 1 Enable

TTL Inputs								
	1	2	3	4	5	6	7	8
State Inverted	<input type="checkbox"/>	<input type="checkbox"/>	<input type="checkbox"/>	<input type="checkbox"/>	<input type="checkbox"/>	<input type="checkbox"/>	<input type="checkbox"/>	<input type="checkbox"/>

TTL Outputs								
	1	2	3	4	5	6	7	8
Browser Control Enabled	<input checked="" type="checkbox"/>	<input checked="" type="checkbox"/>	<input checked="" type="checkbox"/>	<input checked="" type="checkbox"/>	<input checked="" type="checkbox"/>	<input checked="" type="checkbox"/>	<input checked="" type="checkbox"/>	<input checked="" type="checkbox"/>
Plc Control Enabled	<input checked="" type="checkbox"/>	<input checked="" type="checkbox"/>	<input checked="" type="checkbox"/>	<input checked="" type="checkbox"/>	<input checked="" type="checkbox"/>	<input checked="" type="checkbox"/>	<input checked="" type="checkbox"/>	<input checked="" type="checkbox"/>
State Inverted	<input type="checkbox"/>	<input type="checkbox"/>	<input type="checkbox"/>	<input type="checkbox"/>	<input type="checkbox"/>	<input type="checkbox"/>	<input type="checkbox"/>	<input type="checkbox"/>

Send

Copyright © 2008-2012 CAI Networks, Inc.

Figure 5.0 I/O setup

WebControl™ PLC allows user using browser to directly control the output state. If a command line utility or third party control software used, you will need to enable the Browser Control for that TTL output, also may need to go to network configuration to disable the Web login (see figure 4.0).

The inverted state will be remembered in EEPROM even after power loss. The invert state will be restored upon power resumed.

X10 Enable will allow user to send X10RF commands through TTL port7 and TTL port8. Those two ports will not be able to participate any other function, once X10 is enabled.

Counter Enable /Frequency Measurement Enable/TTL Input Enable are radio buttons that you can only select one of them. Those functions sharing the same TTL1 input. Please note the Counter is triggered at rising edge after the falling edge. If your counting source TTL level was zero from start with, you may miss count by 1. Frequency measurement is up to 2MHz .

3.4 X10 RF Control

CAI WebControl PLC



Figure 6.0 WebControl™ X10RF Control

WebControl uses TTL7 and TTL8 to control X10RF devices. User must already enabled X10RF function in the I/O Setup screen. An external RF transmitter must be attached to the output port TTL7, TTL8, and ground. In the USA, the X10 RF frequency is 310MHz, and in Europe, the frequency is 433 MHz. WebControl can send all 16 house codes and 16 unit codes, controlling total 256 devices.

X10 RF function is supported in the PLC programming also.

In PLC programming, PLC command is in the format:

X10 H U C

Where H is house code from 0-F, U is unit code, also from 0-F, C is one of following four commands:

- 0 – Off
- 1 – On
- 2 – Bright
- 3 – Dim

If the X10 function enabled, TTL7 and TTL8 should not be used for controlling other devices. Please note PLC logic uses 0-15 or 0-0xF for code, web GUI only use 0-F.

3.5 Output Control

CAI WebControl PLC

Version: v03.02.09 IpAddress: 192.168.12.15 Name: WEBCONTROL 10/24/2011 13:08:23

Output Control

TTL Outputs		
On	Off	Current State
TTL1 ON	TTL1 OFF	0
TTL2 ON	TTL2 OFF	0
TTL3 ON	TTL3 OFF	0
TTL4 ON	TTL4 OFF	0
TTL5 ON	TTL5 OFF	0
TTL6 ON	TTL6 OFF	0
TTL7 ON	TTL7 OFF	0
TTL8 ON	TTL8 OFF	0

Save States

Copyright © 2011 CAI Networks, Inc.

Figure 6.0 WebControl™ Output Control

When click on each TTL output On or Off, the current state of the TTL output will change. However, the display may or may not update depending on the “Web pulling” enabled in the General Setup screen. If you did not enable the “Web Pulling” to save the bandwidth, you will need to use browser refresh to see the output state change. Please note “Save States” button will make WebControl store the state in the EEPROM. When power lost and reapplied, the output will remember the states being saved.

3.6 Email Notification Setup

WebControl™ allows up to 8 different email notifications to be send from the PLC program. Please note the port can be any number, but WebControl current hardware cannot support SSL enabled email. Certain email servers like Gmail requires use SSL enabled email client. WebControl does not support that. However, WebControl does allow sending email out from port other than 25. Most local ISP provides the non-SSL email server on port other than 25. Please contact your local ISP first to find out how to sending out non-SSL encrypted email. For example, Yahoo email can be used:

SMTP Host = smtp.mail.yahoo.com Port 587

username = your-Yahoo-email-account,

password = your password used

TO field = email address to send TO

From field = Your Yahoo mail

CAI WebControl PLC

Version: v03.02.15	IpAddress: 192.168.1.15	Name: WEBCONTROL	10/14/2011	12:04:38
--------------------	-------------------------	------------------	------------	----------

SMTP Email Setup

System Status	SMTP Host	<input type="text"/>	Port <input type="text" value="25"/>
Output Control	Username (leave blank if none)	<input type="text"/>	
x10 Control	Password (leave blank if none)	<input type="text"/>	
I/O Setup	To Address	<input type="text"/>	
Email Setup	From Address	<input type="text"/>	
Temperature Sensor Setup	Item Starts Not Reporting	EMAIL ALL I/O <input type="button" value="v"/>	
PLC Program	Message ID	Message Subject	Message Body
General Setup	EM1	<input type="text"/>	<input type="text"/> <input type="button" value="Test"/>
Network Setup	EM2	<input type="text"/>	<input type="text"/> <input type="button" value="Test"/>
Help	EM8	<input type="text"/>	<input type="text"/> <input type="button" value="Test"/>

Copyright © 2008-2012 CAI Networks, Inc.

Figure 7.0 WebControl™ email setup

In the 3.2.15 firmware, we allow user to configure less I/O being report. By default, all I/O status is reported in the email.

Most email notification problems are either the configuration problem or the SMTP host rejected email. In this version PLC firmware, user can send a test email to see if

the email notification working or not. In earlier version user guide, it was not clearly stated the email message ID is in format of EM1 through EM8. Using number only or other string may send out wrong email message.

To obtain support for email feature, full TCP capture data is required. The captured data must be able to fully display in WireShark software.

3.7 General Setup

When WebControl™ is connected to the network it will obtain NTP time from Internet. User need to set correct time zone on WebControl™ PLC.

CAI WebControl PLC

Version: v03.02.13 IpAddress: 192.168.1.15 Name: WEBCONTROL 10/14/2011 05:05:29

General Setup

System Status

Output Control

x10 Control

I/O Setup

Email Setup

Temperature Sensor Setup

PLC Program

General Setup

Network Setup

Help

Clock Setup

Time Zone

Set Date Time

Note: time format MM/DD/YYYY HH:MM:SS

Options

UROM1 User defined 32 bit int

UROM2 User defined 32 bit int

UROM3 User defined 32 bit int

UROM4 User defined 32 bit int

TDSO uS (1-Wire Data Sample Timing)

Web Polling Enabled

Copyright © 2008-2012 CAI Networks, Inc.

Figure 8.0 Network defaults

If the WebControl cannot reach to pool.ntp.org over Internet, it will use its own built-in clock with less accuracy. If a DS2417 real time clock chip connected to 1-wire bus, WebControl will query it for the time. User may change and update the clock from this screen by typing MM/DD/YY HH:MM:SS format in the Set Date Time input field, then click “Send” button. If a DS2417 chip is discovered on 1-wire bus, the real time clock will be set to this time. When synced with NTP server, real time clock chip DS2417 is also set every 10 minutes.

UROM1...UROM4 are four identifiers can be used in PLC program. They can help user to fine tune their PLC program for different setup.

For 1-wire devices on a complex bus configuration, its timing is critical. Time Data Sample Offset (TDSO) field is for user making his own timing adjustment based on his setup. Default TDSO is 15uS. For shorter bus, it can be reduced to 14uS or

lower. For longer bus, 16uS or longer may be desirable. 1-wire signals are travelled in CAT5 cable at speed about 20Meter/uS. However, we recommend to add filter resistor to reduce bounced signals from stub wire and far end of the bus, instead of change the timing.

When Web polling enabled, WebControl™ PLC building active Java code will constantly update the browser display for temperature, humidity, and I/O status. Please note with such a update, it may take significant amount bandwidth from your network, as well as WebControl's processor power.

3.8 Reset Setup

If the configuration was totally mess up, user can reset the board to factory default configuration by shorting the RESET holes while powering up the WebControl™. Reset holes on located between Ethernet port and RS-232 connector. Please note reset will wipe out all the configuration, including the PLC program. Please make sure backup your PLC program before reset. After reset, the login ID and password will be restored to “**admin/password**”. Default IP address is 192.168.1.15 with DHCP disabled.

4 AUX System Inputs

The system AUX inputs of WebControl™ are used as inputs to the PLC engine (see section 5.1). This section describes the connector laddled as J12. Digital and analog inputs come through J12 connector.

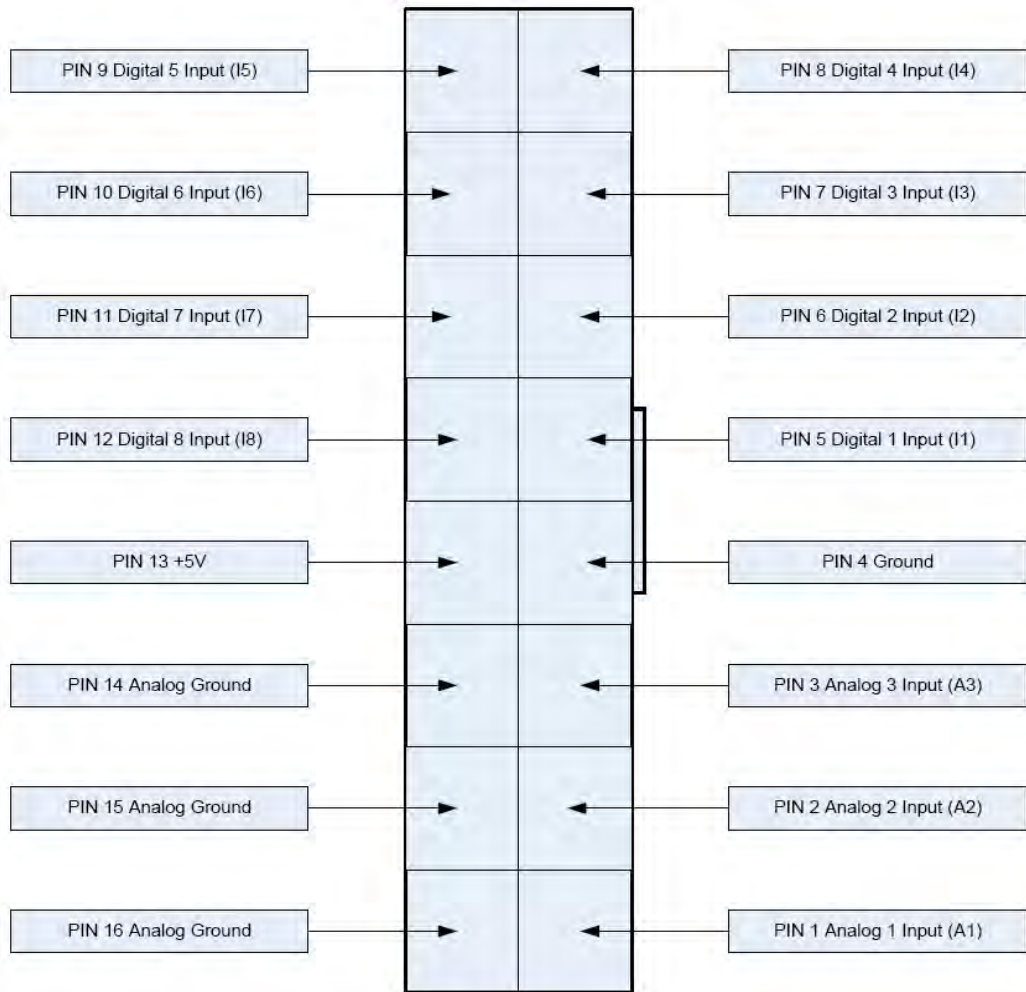

Figure 9.0 WebControl™ J12 Input pins

4.1 Digital Inputs

WebControl™ has eight digital TTL inputs, each of which can be configured to be inverted upon input to the system. The PLC engine will then look for a true or false case of the input. TTL level 0 is defined 0-1.75V; TTL level 1 is defined as 3-5V. When TTL1 being used as counter/frequency measurement purpose, its counts pulses up to 2MHz and max count is 32bit number. Counter starts counts from rising edge after the falling edge.

4.2 Analog Inputs

WebControl™ has three built-in analog inputs each having an input voltage range of 0 to +10V. When a DS2450 chip is connected to the 1-wire bus, additional analog input AIP5,6,7, and 8 are displayed. DS2450 chip has 10 bit resolution and full scale voltage is 0 to +5.0V. Both built-in and optional DS2450 A/D inputs have the full scale range of 0 – 1023. To reduce A/D noise, user may add a 470uF 6.3V capacitor crossing 5V and ground terminal on the J12 header or temperature sensor terminal.

4.3 DS1822/DS18B20 1 Wire Temperature Sensors

WebControl™ supports up to eight Maxim DS1822 /DS18B20 12bit 1 wire temperature sensors. Each temperature sensor must be first assigned a temp sensor number T1-T8.

CAI WebControl PLC

Version: v03.02.09 IpAddress: 192.168.12.15 Name: WEBCONTROL 10/24/2011 13:17:41

Temperature Sensor Setup

- System Status
- Output Control
- x10 Control
- I/O Setup
- Email Setup
- Temperature Sensor Setup
- PLC Program
- General Setup
- Network Setup
- Help

Configured Sensors		
Sensor	ROM Code	Units
T1	22F7401D0000	<input checked="" type="radio"/> °C <input type="radio"/> °F
T2	100853C80108	<input checked="" type="radio"/> °C <input type="radio"/> °F
T3	10E040C80108	<input checked="" type="radio"/> °C <input type="radio"/> °F
T4	22F7401D0000	<input type="radio"/> °C <input checked="" type="radio"/> °F
T5	100853C80108	<input type="radio"/> °C <input checked="" type="radio"/> °F
T6	10E040C80108	<input type="radio"/> °C <input checked="" type="radio"/> °F
T7	000000000000	<input checked="" type="radio"/> °C <input type="radio"/> °F
T8	000000000000	<input checked="" type="radio"/> °C <input type="radio"/> °F

Send

Copyright © 2011 CAI Networks, Inc.

Figure 10.0 WebControl™ Temperature sensor assignments

Each temp sensor has unique ROM code. One temp sensor can be assigned for different sensor number. User can also select the unit as Centigrade or Fahrenheit. If sensor failed later due to sensor failure or wire problem, WebControl™ will display the state as failed, but keep the last valid sensor value. This is to prevent the PLC logic turn on heater/cooler or motor undesirably.

4.4 Honeywell 4000 Series Relative Humidity Sensor

The WebControl™ hardware is designed to support one Honeywell 4000 series relative humidity sensor. The Honeywell sensor output is 'almost' linear voltage between 0 - +5V dc proportional to the relative humidity. This output is fed into one of the A/D converter channels on the microcontroller. CGI command codes are available to setup an upper and lower threshold for the humidity sensor that can then be used in the Boolean expressions.

WebControl PLC has calibrated the humidity curve at 11%, 25%, 45%, and 78%. However, due to sensor differences, some sensors may read the humidity value different from actual value. Adding a 5K linear potentiometer (pot) in series with pin 3 (5V supply line) can help user to adjust your sensor match the accurate humidity reading. If the humidity reading varies a lot, that is an indication your power supply is not providing enough voltage to the board.

4.5 Timers

WebControl™ PLC is different from BRE engine. User must write PLC code to implement timers and delay functions. There is no hard limit of number of timers and delays, There are blocking DELAY and non-blocking delay functions detailed in section 6.2. WebControl PLC has built-in timer reference value for PLC coding:

- ❑ CD Current date mm/dd/yyyy format
- ❑ CT Current time hh:mm:ss format
- ❑ CDW Current day of week
- ❑ CH Current hour of day
- ❑ CM Current minute of hour
- ❑ CS Current second of minute
- ❑ CDAY Current day of month
- ❑ CMONTH Current month of year
- ❑ CYEAR Current year
- ❑ CTS Current Total Seconds

WebControl timer variables are in one mili-second minimum resolution. However, due to high priority I/O like handling, like 1-wire interrupt, the accuracy of the timer may in the range greater than 10mS. For how to program the timer functions, please read Chapter 6 completely. There are a few examples described how to program the WebControl PLC to act based on the input conditions and timer conditions.

4.6 Direct Query System Inputs and Outputs

To integrate with other servers, directly query I/O status maybe desirable. Using wget command from other servers or computers, user can directly query each input and output status. The following HTTP commands are directly return the I/O values:

“geta1.cgi, geta2.cgi, geta3.cgi” – to query analog input values

“geth1.cgi” – to query the humidity sensor readings

“geti1.cgi, geti2.cgi,...geti8.cgi” – to query each digital input values

“geto1.cgi, geto2.cgi,...geto8.cgi” – to query each TTL output status

“gett1.cgi, gett2.cgi,...gett8.cgi” – to query each temperature sensor value

“getts1.cgi, getts2.cgi,...getts8.cgi” – to query each temperature sensor status

“getcounter.cgi” – to query the counter value

“getfcounter.cgi” – to query the frequency measurement per second value.

“getall.cgi” – to query all sensor and I/O status

VAR1-VAR8 can also be set by web UI. Please see FAQ section for how to do that.

5 Real Time Clock

WebControl™ has a build-in clock functions that doing time keeping by using an atomic clock via the simple network timer protocol (SNTP). Configuration is required to set the correct time zone of the clock. When NTP is not available, WebControl™ will use its own crystal to maintain the clock accuracy. If NTP is available, only need to set the time zone in the clock page. If NTP is not available, please set your local clock in the clock page also. Without NTP, its internal clock may not as accurate. Firmware 3.2.9 and later supports DS2417 real time clock IC. Please reference to Maxim-IC web site for DS2417 and its PCB layout recommendation. To build a accurate real time clock, the crystal with exactly the part number listed in the Maxim-IC document is critical.

WebControl will check if a DS2417 existence during power up. Once it finds the DS2417, it will get its clock synced with DS2417 every 10 minutes. User can update the clock in DS2417 by manually go to “General Setup” screen, put the date and time in that field. The DS2417 will get its clock synced up from that. Or, if NTP is working, WebControl will update DS2417 internal clock every 10 minutes.

5.1 Network Requirements to Use the NTP

WebControl™ must be connected to a network that has access to a DNS server. The primary and secondary DNS server addresses of WebControl™ are required to be configured correctly. WebControl™ will use DNS to resolve the name of the timeserver. The NTP server WebControl accessing is pool.ntp.org. If internal NTP server must be used, DNS server must resolve the name record for pool.ntp.org to your local NTP server's IP address.

5.2 Realtime Clock Use DS2417

WebControl™ with firmware 3.2.9 supports DS2417 realtime clock. DS2417 takes one 32.768kHz crystal, EPSON part number C-002RX or C-004R (make sure load capacitance is 6pF). One can easily solder the parts similar to this PCB layout:

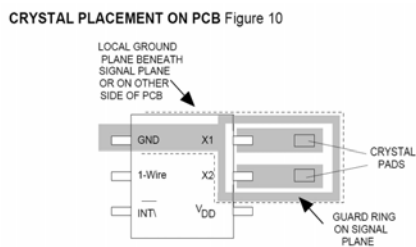

Figure 11.0 DS2417 layout

6 WebControl™ PLC Programming

The WebControl™ PLC firmware can be programmed to execute programmable logic sequences, including comparison and sub routines. This is the major change from the BRE(Booleen Run Engine) version firmware. WebControl™ PLC uses assembly like PLC language. Its main program starts with “START” and finishes with “END”. The PLC program is pasted into the web GUI. WebControl will automatically store it into its EEPROM so that if recycle power will not lose the program. The limitation of the PLC is 1000 line of code. The support for PLC programming is not included in the free support for configuration of WebControl™ PLC.

6.1 The Basics of PLC Programming

WebControl PLC program is NOT hard! We have included many examples toward the end of this chapter. A PLC program is made up of main routine and optional subroutines.

The main routine is enclosed between mandatory START and END instructions e.g.

```
START
#main instructions go here
END
```

To change the logic flow, GOTO instruction can be used as unconditional jump from one section of logic to another without call stack to return. CALLSUB instruction is for unconditional logic flow that may return to the original call stack. BNZ and BZ are conditional GOTO to branch to different section in logic. CNZ and CZ are conditional CALLSUB instruction allowing to return to call stack address.

Both GOTO and CALLSUB use **label** to identify where to execute next instruction. Label can be any string less than 10 characters. Label cannot be identical to any instruction keyword. If sub routines are used then they are coded after the END of the main routine body. Sub routines start at their label and must end with the instruction RET e.g.

```
TEST_IO_SUB:
#instructions here
RET
```

Subroutines can be called from the main program and from within other subroutines. Note that WebControl PLC has a return **program address stack** depth of 8 (or call stack 8).

The program control block has a zero bit that is updated implicitly on TEST instructions. This zero bit is set by any one of these TEST instructions: TSTEQ, TSTNE, TSTGT, TSTLT, TSTGE, TSTLE. This zero bit can also be used implicitly when using branch and call instructions, like BZ, BNZ, CZ, CNZ. E.g. the following test instruction yields a Boolean result which will implicitly set the state of the zero bit. Next a branch instruction is used which branches on the state of the zero bit.

TSTEQ IP1 1 # sets zero bit based on the result of the test instruction
 BNZ label # branches to label if zero bit is non-zero

Format of instructions:

label: (optional)
 opcode operands

Labels must be terminated with a colon ':' and can be a maximum of 10 characters.

6.2 WebControl™ PLC Instructions

The following symbols are used in the table below:

d = destination

a,b..c = operands

() = optional, any operand enclosed in parenthesis mean it is an optional operand.

[] = non-blocking delay operator optional to TTL input/output and VARs. 32 bit unsigned number, represent resolution of 0.001 seconds. When the delay operator is used on input operands the current value of that input is only used if it has had that value for greater than the delay period specified between the brackets. When this operator is used on an output operand the output value is only set for the period specified in the brackets. All delay periods are specified in milliseconds. Note that accuracy and timer resolution is approximately 100ms, even though the delay operator value is in unit of 1mS.

Opcode	Operands	Description
START		Start of main program
TSTEQ	a[] b[] (d[])	Tests if a is equal to b. Boolean result loaded into optional destination (d). Zero bit updated with result. If test evaluates to false then the next instruction is skipped.
TSTNE	a[] b[] (d[])	Tests if a is NOT equal to b. Boolean result loaded into optional destination (d). Zero bit updated with result. If test evaluates to false then the next instruction is skipped.
TSTGT	a[] b[] (d[])	Test if a is greater than b. Boolean result loaded into optional destination (d). Zero bit updated with result. If test evaluates to false then the next instruction is skipped.
TSTLT	a[] b[] (d[])	Tests if a is less than b. Boolean result loaded into optional destination (d). Zero bit updated with result. If test evaluates to false then the next instruction is skipped.
TSTGE	a[] b[] (d[])	Tests if a is greater than OR equal to b. Boolean result loaded into optional destination (d). Zero bit updated with result. If test evaluates to false then the next instruction is skipped.

TSTLE	a[] b[] (d[])	Tests if a is less than OR equal to b. Boolean result loaded into optional destination (d). Zero bit updated with result. If test evaluates to false then the next instruction is skipped.
SET	a[] b[]	Sets I/O id a to the value of b.
ADD	a[] b[] d[]	Adds a and b and puts the result into d. Zero bit updated with result.
SUB	a[] b[] d[]	Subtracts b from a and puts the result into d. Zero bit updated with result.
DIV	a[] b[] d[]	Divides a by b and puts the result into d. Zero bit updated with result.
MUL	a[] b[] d[]	Multiplies a by b and puts the result into d. Zero bit updated with result.
DEC	a	Decrements a by 1. Zero bit updated.
INC	a	Increments a by 1. Zero bit updated.
AND	a[] b[] (d[])	Logical AND's a with b and optionally puts boolean result into d. Zero bit updated.
ANDB	a[] b[] (d[])	Bitwise AND's a with b and optionally puts bitwise AND result into d. Zero bit updated.
OR	a[] b[] (d[])	Logical OR's a with b and optionally puts boolean result into d. Zero bit updated.
ORB	a[] b[] (d[])	Bitwise OR's a with b and optionally puts bitwise OR result into d. Zero bit updated.
XOR	a[] b[] (d[])	Logical XOR's a with b and optionally puts boolean result into d. Zero bit updated.
XORB	a[] b[] (d[])	Bitwise XOR's a with b and optionally puts bitwise result into d. Zero bit updated.
BNZ	(a) b	If the optional a operand is specified it is tested for a non-zero value. If a is not specified then the zero bit is tested for non-zero. If true then program jumps to label specified in operand b.
BZ	(a) b	Same as BNZ but tests for zero value.
CNZ	(a) b	Same as the branch instruction but calls a subroutine instead of branching. See section on program address stack.
CZ	(a) b	Same as above but tests for zero result.
CALLSUB	a	Calls subroutine with label a. See section on program address stack.
GOTO	a	Branches to program address specified by label a.
DELAY	a	Delay instruction, delay specified in 1/1000 seconds. This delay is blocking delay, so that next PLC instruction will not execute until delay is over.
NOP		A no operation instruction.
RET		A return from subroutine instruction.
EMAIL	a	Sends email, a = message ID to send EM1 - EM8.
X10	a b c	a: house code 0-15, b: device code 0-15, c: ON, OFF, BRIGHT, DIM
END		End of main program. This instruction will set the program counter back to zero and the program will start executing from the beginning.

Operands

An operand can be any of the following:

- a signed 32 bit decimal number. e.g. 100 or 1 or 0 etc.
- a hexadecimal number. e.g. 0xABF.
- a date stamp in the format MM/DD/YYYY e.g 02/10/2010
- a time stamp in the format HH:MM:SS e.g. 20:25:00
- a day of week identifier enclosed in single quotes e.g. 'sun'. Day of week identifiers are 'sun' 'mon' 'tue' 'wed' 'thu' 'fri' 'sat'
- an I/O identifier that is a place holder for the real I/O value that the PLC engine will get at runtime. Valid I/O identifiers are explained in next section.

6.3 WebControl™ PLC I/O Identifiers

The following are the valid I/O identifiers

OP1	TTL Outputs 1...8	Valid range 0 - 1
OP2		
OP3		
OP4		
OP5		
OP6		
OP7		
OP8		
IP1	TTL Inputs 1...8	Valid range 0 - 1
IP2		
IP3		
IP4		
IP5		
IP6		
IP7		
IP8		
AIP1	Analog Inputs 1...3	Valid range 0 - 1024
AIP2	AIP1 to AIP3 are built-in A/D converters.	
AIP3		
AIP5	Optional DS2450 provided additional analog inputs.	
AIP6	Please note when DS2450 over range, its output is zero.	
AIP7	When DS2450 disconnected, its value set to 1023	
AIP8		
T1	Temperature sensor inputs 1...8	Valid range -550 - +1250.
T2	Note that temperature values are specifies in 10's of	
T3	degrees. So to test for 21.6 degrees C you would use the	
T4	value 216.	
T5		
T6		
T7		
T8		
TS1	Temperature sensor state 1 or 0.	
TS2	1 == GOOD sensor, 0 == bad sensor	
TS3		
TS4		
TS5		
TS6		
TS7		
TS8		
H1	Humidity sensor	valid range 0 - 100
EM1	Email identifiers 1...8	
EM2		

EM3	
EM4	
EM5	
EM6	
EM7	
EM8	
CD	Current date mm/dd/yyyy format
CT	Current time hh:mm:ss format
CDW	Current day of week
CH	Current hour of day
CM	Current minute of hour
CS	Current second of minute
CDAY	Current day of month
CMONTH	Current month of year
CYEAR	Current year
CTS	Current total seconds since 1/1/2000 (based on local clock)
VAR1	32 bit signed integer variables 1..8
VAR2	The value will be displayed in System Status
VAR3	Delay operator is valid on these
VAR4	It will help debug your program, if you store debug
VAR5	value in VARx.
VAR6	
VAR7	
VAR8	
RAM1	32 bit signed integer general purpose RAM 1..8. Delay
RAM2	operator is not valid on these. Not displayed anywhere
RAM3	
RAM4	
RAM5	
RAM6	
RAM7	
RAM8	
UROM1	32 bit signed integer user value stored in EEPROM
UROM2	read only, value sets through general tab on web GUI.
UROM3	
UROM4	
COUNTER	32 bit counter can be read, compare, or set
FCOUNTER	read only, frequency per second up to 2MHz.

6.4 WebControl PLC Examples

For best understanding how PLC logic working, you can try to copy and paste the examples below into your WebControl PLC program screen to check them out. Please note PLC logic will execute from START to END. Then it will continue from START to END, forever repeating. If you last line of PLC code could skip next instruction,

like those TST instruction, it might skip your first line when condition met. Please do pay attention to it. If you use CALLSUB to run subroutine, after finishing the subroutine, the logic will return back to where CALLSUB called and continue.

6.4.1 Example 1 Set Output based on condition

Control incubator heater connected to TTL output 1. If temperature T3 is less than 37 degree C turn ON the heater; if T3 is greater or equal to 39 degree C, turn the heater OFF,.

```
START
    TSTLE T3 370 OP1
    NOP
    TSTGT T3 389
    SET OP1 0
END
```

However, this does not work, when temperature reached above 37 degree C, the OP1 turned off, instead of reaching to 39 degree C. The problem is the OP1 can be set to ON or OFF by the “TSLE T3 370 OP1” line alone. To reduce heater relay constantly turning ON and OFF, it is better to have two subroutines to handle the OP1 state.

```
START
    TSTLE T3 370
    CALLSUB HEAT_ON
    TSTGT T3 389
    CALLSUB HEAT_OFF
END
```

```
HEAT_ON:
    SET OP1 1
RET
```

```
HEAT_OFF:
    SET OP1 0
RET
```

What if the heater relay stuck, or the heater elements burn out? You can add additional function in this PLC program to send you email notice or sound an alarm for such a situation.

6.4.2 Example 2: Flash TTL output

Flashes output 2 at a rate of 1Hz. (Please note OP2[500] has no space in between which delays 500ms). Please note the delay function used in this example, which is non-blocking, that means the PLC logic will immediately execute next TSTEQ instruction until the delay is over.

```

START
    TSTEQ OP2[500] 0
    SET OP2 1
    TSTEQ OP2[500] 1
    SET OP2 0
END

```

Another way to implement this is:

```

START
    XOR OP2 1 OP2
    DELAY 500
END

```

6.4.3 Example 3: Push Button Input Control Output

When a push button connected to TTL input 1 being pushed, set the TTL output 3 ON.

```

START
    TSTEQ IP1 1 OP3
    TSTEQ OP3 1
    SET OP3 0
END

```

Although this example works, it has flaw. Because all the pushbutton switches from market will not have clean instant ON or OFF, they actually produce a bunch of ON and OFF signals when pushed. If you use a scope to watch IP1 input line or OP3 output line, you will see they are many ON and OFF pulses during pushing or releasing the button. The better way to handle the case is like Example 10 later in this manual. However, if TTL OIP1 connected to a clean signal source, this example does work well.

6.4.4 Example 4: Send EMAIL

To send email 1 when $T3 - T2 \geq 20$ degrees you would use:

```

START
    SUB T3 T2 RAM1
    TSTGE RAM1 200
    EMAIL EM1
END

```

The above rule is a bit too simple because an email will constantly be generated while

RAM1 is greater than or equal to 200. (20 degrees in this case) To guard against that the following logic should be considered. This implementation will only send one email when the temperature comparison beyond the range. If you turn on heater or cooler instead of sending email, similar consideration also should be excised:

```

START
    SET RAM2 0
LOOP:
    SUB T3 T2 RAM1
    TSTGE RAM1 200 RAM1
    GOTO SEND
    SET RAM2 0
    GOTO LOOP
END

SEND:
    BNZ RAM2 LOOP
    SET RAM2 1
    EMAIL EM1
    GOTO LOOP

```

Please note in SEND portion of the code, RAM2 is being checked, if it is already 1, it will skip sending email. Only when RAM2 == 0, an email will be send. Only when RAM1 < 200, the LOOP will skip SEND logic and reset RAM2 to 0.

6.4.5 Example 5, Parallel I/O

This simple program performs 4 separate I/O checks and sets OP1 to OP4 states. In this example, we use subroutine feature of the PLC logic. Although in this case, GOTO can do same thing as CALLSUB, CALLSUB can help program more readable. In certain logic, you have to use CALLSUB instead of GOTO, depending on the logic flow. We will explain more when we run into those examples.

The logic in this example follows:

```

OP1 is set if T3 > 50
OP1 is cleared if T3 < 50
OP2 is set if IP1 == 1 for more than 300ms
OP2 is cleared if IP1 == 0
OP3 is set if AIP1 + AIP2 > 1024
OP3 is cleared if IP4 == 1
OP4 is set if OP1 == 1
OP4 is cleared if OP1 == 0

```

The PLC code written for the above scenarios would be as follows:

```
START
    CALLSUB checkOP1
    CALLSUB checkOP2
    CALLSUB checkOP3
    CALLSUB checkOP4
END

checkOP1:
    TSTGT T3 500 OP1
    RET

checkOP2:
    TSREQ IP1[300] 1 OP2
    RET

checkOP3:
    ADD AIP1 AIP2 RAM1
    TSTGT RAM1 1024
    BNZ I1
    TSREQ IP4 1
    BNZ I2
    RET

I1:
    SET O3 1
    RET

I2:
    SET O3 0
    RET

checkOP4:
    TSREQ OP1 1 OP4
    RET
```

Please note in this example, we assume the TTL input, analog input and temperature reading are all perfect, no bouncing up and down. In reality, you have to add consideration to it.

6.4.6 Example 6, Sequential I/O

The following simple program shows how to set-up sequential I/O.

```
OP1 is set when IP1 rises from 0 to 1
OP4 is cleared when IP1 rises from 0 to 1
```

OP1 is cleared when O4 == 1
 OP2 is set when T3 > 25 AND OP1 == 1
 OP2 is cleared when OP1 == 0
 EMAIL1 is sent when OP2 is set
 O4 is set when OP2 == 1 for more than 1 second

The assembly language written for the above scenario would be as follows:

```

START
  BNZ IP1 start
11:
  TSTEQ IP1 1
  BZ 11
  SET OP1 1
  SET OP4 0

12:
  TSTGT T3 250 RAM1
  AND OP1 RAM1
  BZ 12
  SET OP2 1
  EMAIL EM1

13:
  TSTEQ OP2[1000] 1
  BZ 13
  SET OP4 1
  SET OP1 0

END

```

Please note in this example, we assume the TTL input, analog input and temperature reading are all perfect, no bouncing up and down. In reality, you have to add consideration to it.

6.4.7 Example 7, Traffic Lights

This example will let pedestrian to push a button to change the light on a busy street, so that he can cross the street safely. IP1 hooks up to the pedestrian crossing button. If someone pushed cross button, the street will have amber light on for 10 seconds, then red light to stop all the cars, allowing pedestrian to cross street in next 30 seconds. At the end of 30 seconds, it will flash the amber and red light for 5 seconds. VAR1 in the main program will let the crossing light turn on every 100 seconds, does not matter anybody push the crossing button or not.

OP1 Red + Pedestrian crossing light
 OP2 Amber
 OP3 Green
 IP1 Pedestrian Push Button

```
START
  CALLSUB LIGHTS_GO
loop:
  SET VAR1[10000] 1
loop1:
  TSTEQ IP1 1
  BNZ sr
  BZ VAR1 sr
  GOTO loop1
sr:
  CALLSUB STOP
  GOTO loop
END
```

```
LIGHTS_ST:
  SET OP1 1
  SET OP2 0
  SET OP3 0
  RET
```

```
LIGHTS_GO:
  SET OP1 0
  SET OP2 0
  SET OP3 1
  RET
```

```
LIGHTS_AM:
  SET OP1 0
  SET OP2 1
  SET OP3 0
  RET
```

```
STOP:
  CALLSUB LIGHTS_AM
  DELAY 5000
  CALLSUB LIGHTS_ST
  DELAY 60000
  CALLSUB LIGHTS_AM
  SET RAM2 5
flash:
  XOR OP2 1 OP2
  DELAY 500
  DEC RAM2
  BNZ flash
  CALLSUB LIGHTS_GO
  RET
```

6.4.8 Example 8, Time based Control

WARNING: For time critical application, please make sure to check CYEAR correct before taking action based on system clock. When WebControl™ boot up, it will uses ROM hard coded time in 2011. If PLC reporting year 2011, the NTP or real time clock has not sync the local clock yet.

This example will have five subroutines. WebControl™ PLC will continuously loop through them. The “HOURLY” routing will compare analog input 1 and analog input 2, if $A1 - A2 > 10$, send an email notice 1. You can use similar logic to adjust your solar panel orientation each hour, etc. The “PERIOD” subroutine will turn on night light hooked up to OP1 after 18:00 hours and turn it off at 5AM. The “DAILY” subroutine will start the water sprinkler at 6:30AM for four zones. The “MONTHLY” routing will check the “salt low” sensor AIP3 on the water softener and send email notice 2. The “YEARLY” routing will ring the New Year’s bell connected to OP6 on each and every New Year’s Day for the whole day!

```

START
    CALLSUB HOURLY
    CALLSUB PERIOD
    CALLSUB DAILY
    CALLSUB MONTHLY
    CALLSUB YEARLY
END

HOURLY:
    TSTNE RAM1 CH
    GOTO T1
RET

T1:
    SET RAM1 CH
    SUB AIP1 AIP2 RAM2
    TSTGT RAM2 10
    EMAIL EM1
RET

PERIOD:
    TSTGE CH 18 RAM2
    NOP
    TSTLE CH 5 RAM3
    NOP
    OR RAM2 RAM3 OP1
RET

DAILY:
    TSTEQ CH 7
    SET RAM5 0

```

```
TSTEQ CH 6
BZ NOTYET
TSTGT CM 30
CALLSUB WATERING
NOTYET:
RET

MONTHLY:
TSTNE RAM4 CMONTH
GOTO T2
RET

T2:
TSTLE CH 8
GOTO 2EARLY
SET RAM4 CMONTH
TSTLT AIP3 20
EMAIL EM2

2EARLY:
RET

YEARLY:
TSTEQ CMONTH 1 RAM2
NOP
TSTEQ CDAY 1 RAM3
NOP
AND RAM2 RAM3 OP6
RET

WATERING:
BNZ RAM5 W_DONE
ZONE1:
SET OP2 1
TSTLE CM 35
GOTO ZONE1
SET OP2 0
ZONE2:
SET OP3 1
TSTLE CM 40
GOTO ZONE2
SET OP3 0
ZONE3:
SET OP4 1
TSTLE CM 45
GOTO ZONE3
SET OP4 0
ZONE4:
SET OP5 1
TSTLE CM 50
GOTO ZONE4
SET OP5 0
SET RAM5 1
W_DONE:
RET
```

Please note in DAILY subroutine, we call another subroutine “watering”. In this place, we have to use subroutine, since we only want to call this routine after 6:30AM. If current minute is not 30, we will skip. Watering will be done before 7AM, so that we clear the flag RAM5 at 7AM. Also, please notice RAM1, RAM4 and RAM5 are holding static value and RAM2 and RAM3 are temporary storage being used by more than one subroutine. You can decide which RAM is for temporary data, which is for static value.

In the PERIOD subroutine, we constantly compare the time and set the OP1 ON or OFF. That is okay for solid state relay or other control relay, since the logic level did not change all the time. However, if you are sending a X10 command to turn on and off different lights, you want to make sure the X10 command only issued once, not repeatedly. You may create another subroutine in which set flag only calls X10 1 15 ON only once to turn ON light at house code 2, unit code 16 (please note WebControl’s X10 house code range 0-F, and device code range also 0-F.)

In the MONTHLY routine, we first check the current hour being 8AM then we check the water softener’s salt level. In this way you will not be waked up by email in the midnight.

When program WebControl PLC for time based logic, please make sure the time being used in different part of the program having no conflict between all the subroutines. If you want two things to happen at the same time, you should consider combine them into same routine to handle.

6.4.9 Example 9, Battery Charger

This is a PLC program to charge 3 serially connected NIMH batteries. First, it tries to discharge the batteries individually. If any battery discharged to 1V, it will stop the discharge and start charging. When each cell is being charged to 1.25V, it will stop charging. We assume the A1, A2, and A3 being calibrated to 1V=100. The measurement on the battery 2 is the total voltage of battery 1 and battery 2. And the measurement on battery 3 is the total voltage of all three batteries. This example will individually discharge and charge each battery.

```

start
    set op1 1
    set op2 1
    set op3 1
    set RAM1 0
    set RAM2 0
    set RAM3 0
loop:
    cnz op1 check_b1
    cnz op2 check_b2
    cnz op3 check_b3
goto loop
end
check_b1:
    BNZ RAM1 c1
    tstle AIP1 100 RAM1
    bz e1
c1:

```

```

        tstgt AIP1 125
        bnz e1
        set op1 0
        set op4 1
e1:
ret
check_b2:
    BNZ RAM2 c2
    sub AIP2 AIP1 RAM4
    tstle RAM4 100 RAM2
    bz e2
c2:
    sub AIP2 AIP1 RAM4
    tstgt RAM4 125
    bnz e2
    set OP2 0
    set OP5 1
e2:
ret
check_b3:
    BNZ RAM3 c3
    sub AIP3 AIP2 RAM4
    sub RAM4 AIP1 RAM4
    tstle RAM4 100 RAM3
    bz e3
c3:
    sub AIP3 AIP2 RAM4
    sub RAM4 AIP1 RAM4
    tstgt RAM4 125
    bnz e3
    set OP3 0
    set OP6 1
e3:
ret

```

6.4.10 Example 10, RFID reader and browser Control

For office door using RFID reader, as well as allowing operator remote browser control, the following program provided the example. RFID reader's NC (normally connect) output connects to IP1 on WebControl digital input. A 2.2K pull-up resistor also connected between IP1 and 5V. In this way, each time a valid RFID tag sensed, a TTL "1" feeds to WebControl IP1. Remote operator can also open the door by using browser set OUTPUT TTL1 to on. OP1 connects to the door open switch. TESTEQ logic will make sure the OP1 is an 1 second momentary output.

"LIGHTS" subroutine is for light control outside the office door; the light is on at 7PM and off at 5AM.

```

START
    CALLSUB LIGHTS

```

```
    TSTEQ RAM1 0
    CALLSUB SET_OP1
    CALLSUB CHK4LOW
    TSTEQ OP1[1000] 1
    SET OP1 0
END

CHK4LOW:
    TSTEQ IP1 0
    SET RAM1 0
    RET

SET_OP1:
    TSTEQ IP1 1 RAM1
    SET OP1 1
    RET

LIGHTS:
    TSTGE CH 19 RAM2
    NOP
    TSTLE CH 5 RAM3
    NOP
    OR RAM2 RAM3 OP3
    RET
```

In this logic, SET_OP1 must be subroutine, if “TSTEQ RAM1 0” it will call the subroutine SET_OP1, but if RAM1 != 0, then it will skip that call. In this way, we can guarantee OP1 only being turn on once. In the subroutine SET_OP1, it checks if RFID reader did detected valid RDID card present. If so, it will set the flag RAM1 to true, so that not being set over and over again. For gate opening device, this will make sure the gate will not left open all the time.

6.4.11 Example 11, Your Examples

The use of WebControl in Industrial automation, office automation and home automation are almost endless. You can submit your example to us for sharing it with other users.

7 WebControl™ PLC FAQ

We include some users frequently asked questions here:

7.1 Login and Configuration

1-1Q: Can you tell me how to connect with Windows Explore? I cannot communicate?

1-1A: If you have DHCP server on your network, please check with your DHCP server log, WebControl is likely obtained an IP address from your DHCP server. Once you find out the IP address assigned by DHCP server, you can use browser to connect to:

`http://what-ever-dhcp-assigned-ip/`
You will see the login screen.

If you don't have DHCP server on your network, WebControl's default IP address is 192.168.1.15. You must change your computer's IP address temporarily to 192.168.1.1, (make sure no other host using that IP address on your network), then from IE browser enter:

`http://192.168.1.15/`
You will see the login screen.

1-2Q: I have problem to setup the clock, it does not work, even I setup my network and DNS server correctly?

1-2A: Please check with your ISP to make sure the DNS server IP address is valid. If you have Linux computer, you can use dig command to make sure that DNS server IP can resolve the ntp.org. Please note that many ISPs restrict the DNS access from outside its own IP address range. If your DNS server IP is not from your ISP, it may not work.

`dig ntp.org @your-dns-server-ip`

1-3Q: What is the default user ID and password, can I change it?

1-3A: The default user ID and password is admin/password, all lower case. User can change both user ID and password.

7.2 Temperature Sensor Support

2-1Q: The document stated supporting DS1822/DS1820 1 Wire Temperature Sensors, I assumed the whole DS18xx family of devices would work. I used a DS18S20+ and get about 3.5 degrees C when powered, 10.6 when parasitic powered. It should read 23-24 at room temperature. For power I tried pin 3 of the temperature terminal and pin 3 of the humidity terminal and the result is the same.

2-1A: WebControl™ can simultaneously connect 8 optional DS18B20/DS1822/DS18S20 based digital temperature sensors. In the past we require 12bit temperature sensor. Now, we lose the requirement to 12bit and 9 bit Maxim-IC temp sensors. We still do not support parasite part.

2-2Q: How to read temperature or sensor ROM code from command line in Linux?

2-2A: Use `wget http://webcontrol-ip/gett1.cgi` to read the temp sensor T1, and use `wget http://webcontrol-ip/gett1rc.cgi` to read the sensor T1 ROM code.

2-3Q: What can cause my temperature sensor not display correctly?

2-3A: Use solid copper wire for your 1-wire bus. Reduce any unnecessary length of the wire. Do not hook up unsupported parts to the 1-wire bus, since they may generate 1-wire signal causing trouble.

2-4Q: I run a long cable between the DS18B20 and WebControl, sensor does not work?

2-4A: According to Maxim-IC, if using a long cable connecting between the sensor and host controller, it may require to add a pull-up resistor 4.7k from 1-wire bus (DQ pin on DS18B20) to the 5V supply near the far end of the 1-wire bus. Please check out [Maxim-IC AppNote148](#)

7.3 Turn on/off TTL output from another programming language

3-1Q: I want to turn on/off TTL output from Visual Basic, can I do it?

3-1A: You can reference how the browser does it and emulate that in your VB or script. Please make sure to disable login in the "Network Setup" screen. For security purpose, please specify the IP address in the access list. Depends on the IP address and which TTL you want to control by programming language, you may refer to these two browser URL lines:

`http://192.168.1.15/api/setttloutput.cgi?output=1&state=1` to turn on,

`http://192.168.1.15/api/setttloutput.cgi?output=1&state=0` to turn off.

and to manually set a VAR value from outside:

`http://192.168.1.15/api/setvar.cgi?varid=1&value=23456789`

Command line browser `wget` can be used to do manually control. The above lines maybe need in double quotes to work.

7.4 External Analog Chip DS2450

4-1Q: I have DS2450 on the 1-wire bus, but reading is not stable?

4-1A: Maxim-IC DS2450 known for its sensitivity to noise. Please make sure to add 100pF disc capacitors across the chip on its VDD to ground, and from each analog input immediately to the ground, also. Any analog input channel should have 1K input resistor to block some the incoming noise.

7.5 Power Supply Requirement

5-1Q: What kind of power required to run WebControl?

5-1A: WebControl 2.2.2 hardware can operate from 7.5 to 12VDC power supply. However, when using DC12V, the regulator will be VERY hot. It is recommended to run on 9VDC1A power supply. Please make sure power supply has good filtering capacitors. Any noise in the power supply could cause problem during execution of WebControl PLC logic. If a relay board is also used with WebControl, please make sure the power supply has enough reverse current to handle the spike during relay switching.